

**UltraTrex**  
AMPHIBIOUS EXCAVATOR

# ULTRATREX AT200ER-V2

UTX, YOUR TRUSTED PARTNER IN  
SHALLOW DREDGING EQUIPMENT



**ULTRATREX MACHINERY SDN. BHD.**



CERT NO. : TUV 100-01-2043  
ISO 9001 :2015



**Tel: +607-355 7777**

**Fax: +607-351 0229**

**Email: [marketing@ultratrex.com.my](mailto:marketing@ultratrex.com.my)**

[www.amphibousexcavator.com](http://www.amphibousexcavator.com)



**INTRODUCTION**

Ultratrex amphibious excavator is an excavator that can travel and work safely and effectively on soft terrain such as swamp, wet land and shallow water. The well designed amphibious hydraulic undercarriage has ultra-low ground pressure and unparalleled mobility to work on soft terrains and swamps area



**FEATURES**

**Track plates**

- Ultra High Molecular Weight Polyethylene (UHMWPE)
- High strength and quality material.
- 10000 Hours warranty

**Gear Rack Spud**

- High precision rack gear teeth and pitch
- Robust design to give stabilization while digging in deeper water.

**Grease Tensioner System**

- Easire method chain tensioning system rather than convensional system by using spanner
- Using grease to move chain tensioning cylinder

**Amphibious Undercarriage construction**

- Anti corrosion plate SMA 490
- 3 independent water compartments
- Reinforce bottom area

**Track Chains**

- Triple strands
- Track chain pitch : 152.4 mm
- Running on hardox AR400 wear plate

**Amphibious Undercarriage Hydrostatic Drive**

- Brand: Bonfiglioli
- Origin: Italy
- Integrated hydraulic 2 speed motors
- Output torque: 3059kgf.m

**APPLICATION**

- Swamp land clearing at mining, plantation and forest area.
- Deepening of canal, river channel and river mouth.
- Building bund for flood prevention and reclamation
- Sludge clearing of lakes, ponds and water reservoir
- Digging trenches for oil and gas piping installation
- Transporting and clearing land slide and flood hit area
- Swamps and wetlands construction
- Road construction through wetland.



CERT NO. : TUV 100-01-2043  
ISO 9001 :2015





**TECHNICAL SPECIFICATION**

**EXTEND POSITION:**

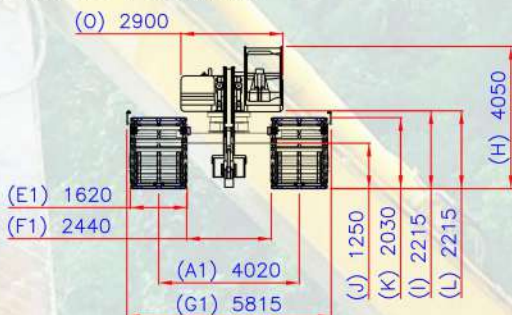

<b>BASE MACHINE</b>	<b>20 TON CLASS</b>
<b>TOTAL WEIGHT</b>	<b>32000 Kg</b>
<b>FLOAT CAPACITY</b>	<b>40 m3</b>

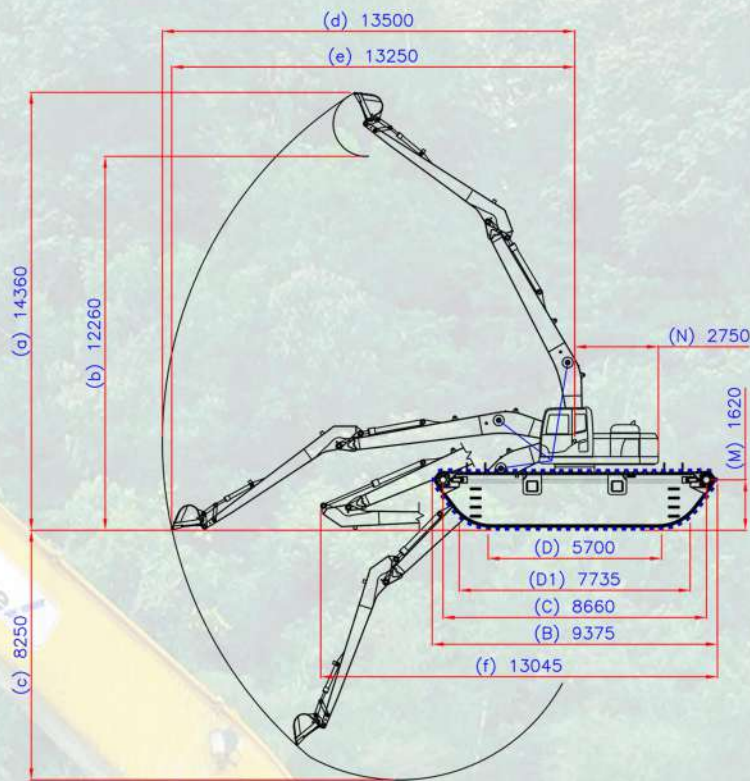

ITEM	UNIT	VALUE
TRAVEL SPEED	HI	km/h 3.6
	LO	km/h 2.3
MAXIMUM GRADIENT	°	30
WORK EQUIPMENT	BOOM LENGTH	mm 7750
	ARM LENGTH	mm 5150
	BUCKET CAPACITY	m <sup>3</sup> 0.5
WORKING RANGE	a. MAX. DIGGING HEIGHT	mm 14360
	b. MAX. DUMPING HEIGHT	mm 12260
	c. MAX. DIGGING DEPTH	mm 8250
	d. MAX. DIGGING REACH	mm 13500
	e. MAX DIGGING REACH ON GROUND	mm 13250
	f. TOTAL LENGHT DURING PARKING	mm 13045
DIMENSIONS	A. TRACK GAUGE (FULLY RETRACTED)	mm 2760
	A1. TRACK GAUGE (FULLY EXTENDED)	mm 4020
	B. TRACK LENGTH	mm 9375
	C. DISTANCE BETWEEN IDLER & SPROCKET	mm 8660
	D. TRACK LENGTH ON HARD GROUND	mm 5700
	D1. TRACK LENGTH ON SOFT GROUND	mm 7735
	E. WIDTH TRACK SHOE	mm 1590
	E1. WIDTH FLOAT	mm 1620
	F. DISTANCE BETWEEN SHOE INSIDE (FULLY RETRACTED)	mm 1170
	F1. DISTANCE BETWEEN SHOE INSIDE (FULLY EXTENDED)	mm 2440
	G. OVERALL MACHINE WIDTH (FULLY RETRACTED)	mm 4575
	G1. OVERALL MACHINE WIDTH (FULLY EXTENDED)	mm 5815
	H. OVERALL MACHINE HEIGHT	mm 4050
	I. GROUND CLEARANCE (COUNTERWEIGHT)	mm 2215
	J. MIN. GROUND CLEARANCE	mm 1250
	K. SHOE SETTING HEIGHT	mm 2030
	L. CRAWLER HEIGHT	mm 2215
	M. WATER LINE LEVEL	mm 1620
	N. MIN SWING RADIUS	mm 2750
O. CABIN WIDTH	mm 2900	

<b>GROUND PRESSURE</b>	<b>0.18 Kg/cm<sup>2</sup></b>
<b>MAXIMUM TORQUE</b>	<b>3059 Kgf.m</b>
<b>FLOAT CAPACITY/ TOTAL WEIGHT</b>	<b>1.25 m3/ton</b>

**RETRACT POSITION:**

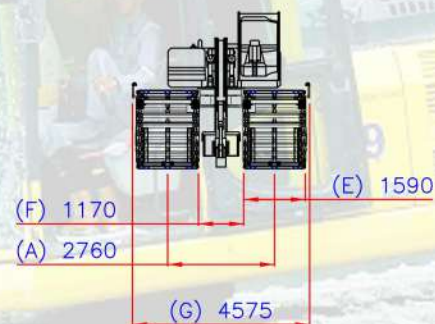

\* Specification are subject to change without prior notice  
 \* All dimensions are without side pontoon and spud  
 \* Dimension are based on 13.5 m long reach arm and 0.5m<sup>3</sup> GP bucket



# ULTRATREX MACHINERY SDN. BHD.



**ULTRATREX MACHINERY SDN. BHD.**

**TEL : +607 355 7777**

**FAX : +607 351 0229**

**HP : +6016 772 0584**

**E-MAIL : [marketing@ultratrex.com.my](mailto:marketing@ultratrex.com.my)**

**PLO 229, JALAN KENCANA MAS 2,  
KAWASAN PERINDUSTRIAN TEBRAU 3,  
81100 JOHOR BAHRU, JOHOR, MALAYSIA.**

[www.amphibiousexcavator.com](http://www.amphibiousexcavator.com)